

Black Tripod Studio Lamp with Gold Leaf Shade



## LIGHT SOURCE DATA

- 60W Max E27 ES (required)
- Lamp direction - Upwards
- Lamp shape - Standard
- Non-dimmable
- Energy class: Not applicable

## DIMENSION DATA

- Height 1500mm
- Diameter 410mm
- Weight 2.86kg

## SPECIFICATION

- Manufacturer warranty for 2 years from date of purchase
- Black with gold leaf detail
- IP20
- In-line On/Off Switch
- Class II - Double Insulated, No Earth
- 240V
- Assembly required? Yes
- CE Marking, UKCA Marking, Energy Efficient, Energy Saving

## CERTIFICATION



## CONTACT

[www.firstchoicelighting.co.uk](http://www.firstchoicelighting.co.uk)

[info@firstchoicelighting.co.uk](mailto:info@firstchoicelighting.co.uk)

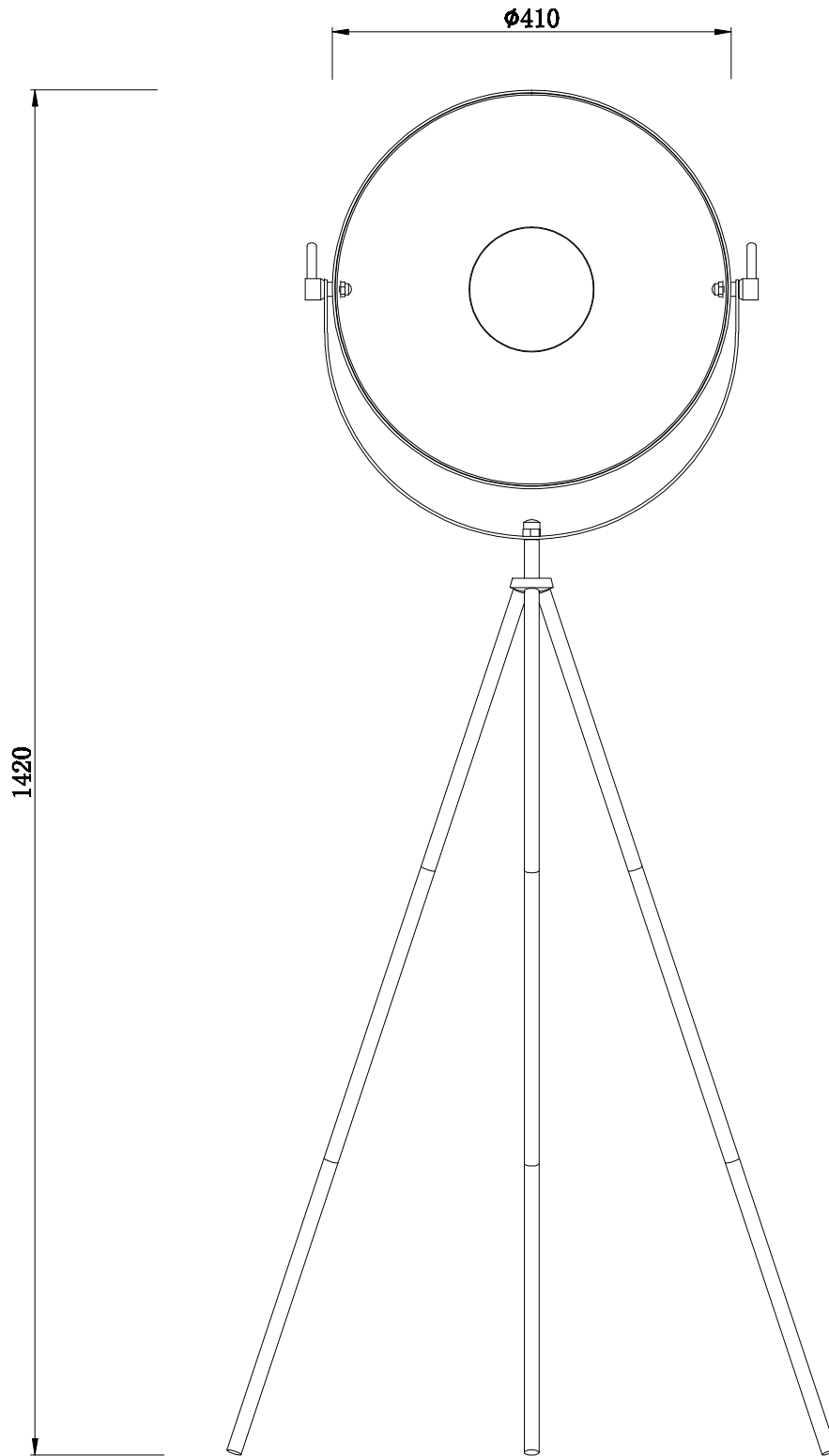

## CERTIFICATION



## CONTACT

[www.firstchoicelighting.co.uk](http://www.firstchoicelighting.co.uk)

[info@firstchoicelighting.co.uk](mailto:info@firstchoicelighting.co.uk)