



LIGHT SOURCE DATA

- 60W Max E27 ES (required) & 25W Max E14 SES (required)
- Lamp direction - Upwards
- Lamp shape - Standard
- Non-dimmable
- Energy class: Not applicable

DIMENSION DATA

- Height 1720mm
- Width 320mm
- Depth 245mm

- Weight 2.71kg

SPECIFICATION

- Manufacturer warranty for 2 years from date of purchase
- Silver and white PP diffuser
- IP20
- In-line On/Off Switch
- Class II - Double Insulated, No Earth
- 240V
- Assembly required? Yes
- CE Marking, UKCA Marking, Energy Efficient, Energy Saving

CERTIFICATION



CONTACT

www.firstchoicelighting.co.uk

info@firstchoicelighting.co.uk

FCL-10841

Silver Painted Mother & Child Lamp

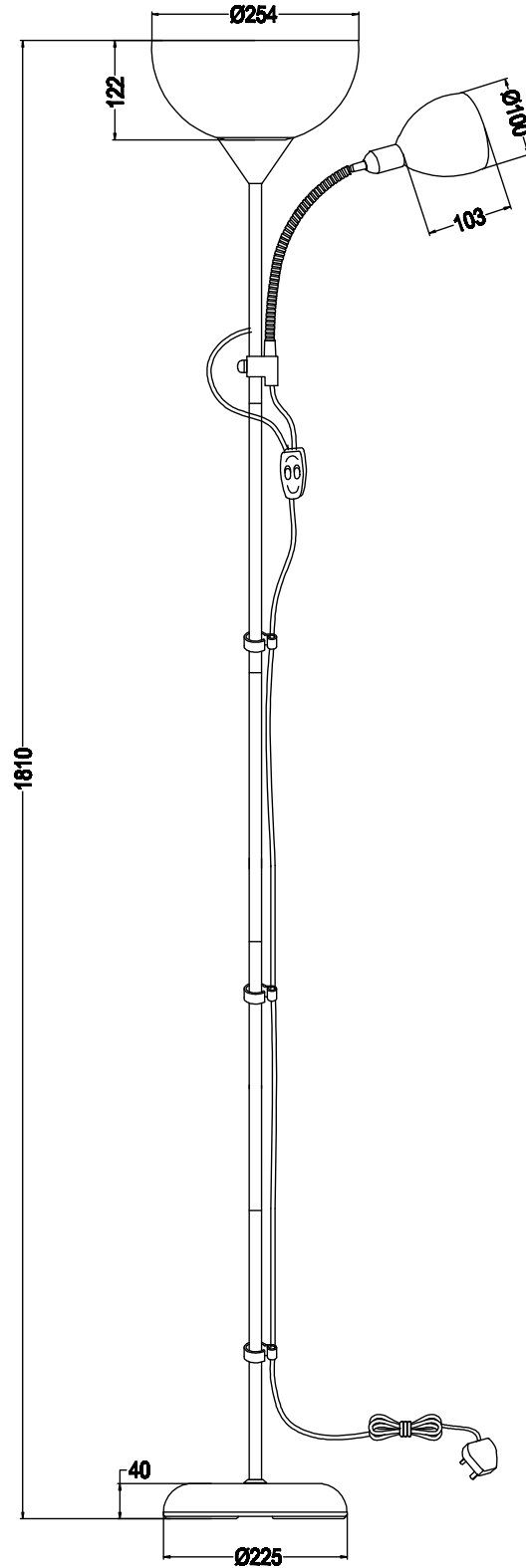

CERTIFICATION



CONTACT

www.firstchoicelighting.co.uk

info@firstchoicelighting.co.uk

ISSUE DATE 16/02/2023

PAGE 2