



LIGHT SOURCE DATA

- 40W Max E14 SES (required)
- Lamp direction - Indirect
- Lamp shape - Standard
- Non-dimmable
- Energy range: A++, A+, A, B, C, D, E

DIMENSION DATA

- Height 390mm
- Diameter 260mm
- Weight .82kg

SPECIFICATION

- Manufacturer warranty for 2 years from date of purchase
- Polished chrome plate and textured grey cotton
- IP20
- Touch On/Off Switch
- Class II - Double Insulated, No Earth
- 240V
- Assembly required? No
- Black flex and plug
- CE Marking, Energy Efficient, Energy Saving

CERTIFICATION



CONTACT

www.firstchoicelighting.co.uk

info@firstchoicelighting.co.uk

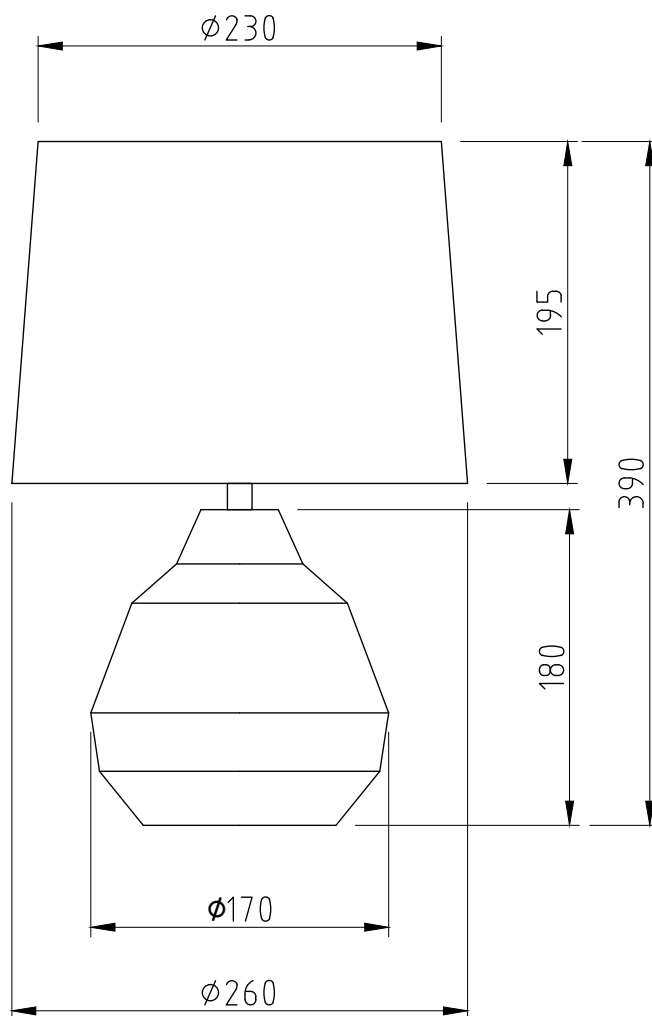

CERTIFICATION



CONTACT

www.firstchoicelighting.co.uk

info@firstchoicelighting.co.uk