



LIGHT SOURCE DATA

- 2 x 35W Max GU10 Halogen (required)
- Lamp direction - Upwards
- Lamp shape - Reflector/Pear Shape
- Dimmable
- Energy class: Not applicable

DIMENSION DATA

- Height 12.3mm
- Diameter 110mm
- Projection 6.5mm
- Minimum cavity depth 120mm
- Cut out size 92mm
- Weight 1kg

SPECIFICATION

- Manufacturer warranty for 2 years from date of purchase
- Brushed stainless steel and clear glass
- IP44
- No
- Class I - Single Insulated, Earthed
- 240V
- Assembly required? No
- Comes with 300mm black rubber shrouded cable
- CE Marking, UKCA Marking, Energy Efficient, Energy Saving

CERTIFICATION



CONTACT

www.firstchoicelighting.co.uk

info@firstchoicelighting.co.uk

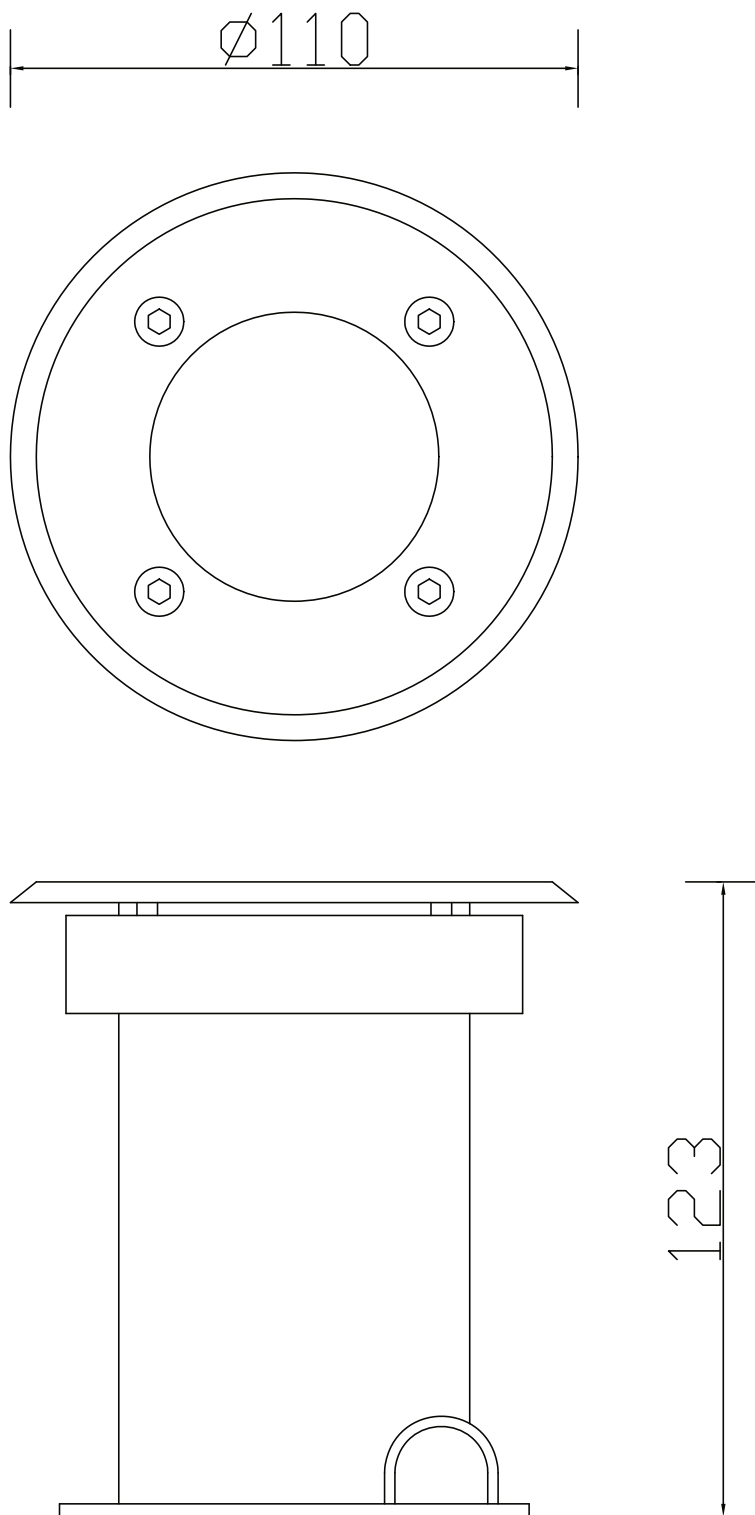

CERTIFICATION



CONTACT

www.firstchoicelighting.co.uk

info@firstchoicelighting.co.uk