

**LIGHT SOURCE DATA**

- 40W Max E14 SES (required)
- Lamp direction - Indirect
- Lamp shape - Standard
- Non-dimmable

**DIMENSION DATA**

- Height 290mm
- Diameter 175mm
- Weight .75kg

**SPECIFICATION**

- Manufacturer warranty for 2 years from date of purchase
- White glaze and grey cotton
- IP20
- In-line On/Off Switch
- Class II - Double Insulated, No Earth
- 240V
- Assembly required? No
- 1.3m length cable from base to plug
- CE Marking, UKCA Marking, Energy Efficient, Energy Saving

**CERTIFICATION****CONTACT**

[www.firstchoicelighting.co.uk](http://www.firstchoicelighting.co.uk)

[info@firstchoicelighting.co.uk](mailto:info@firstchoicelighting.co.uk)

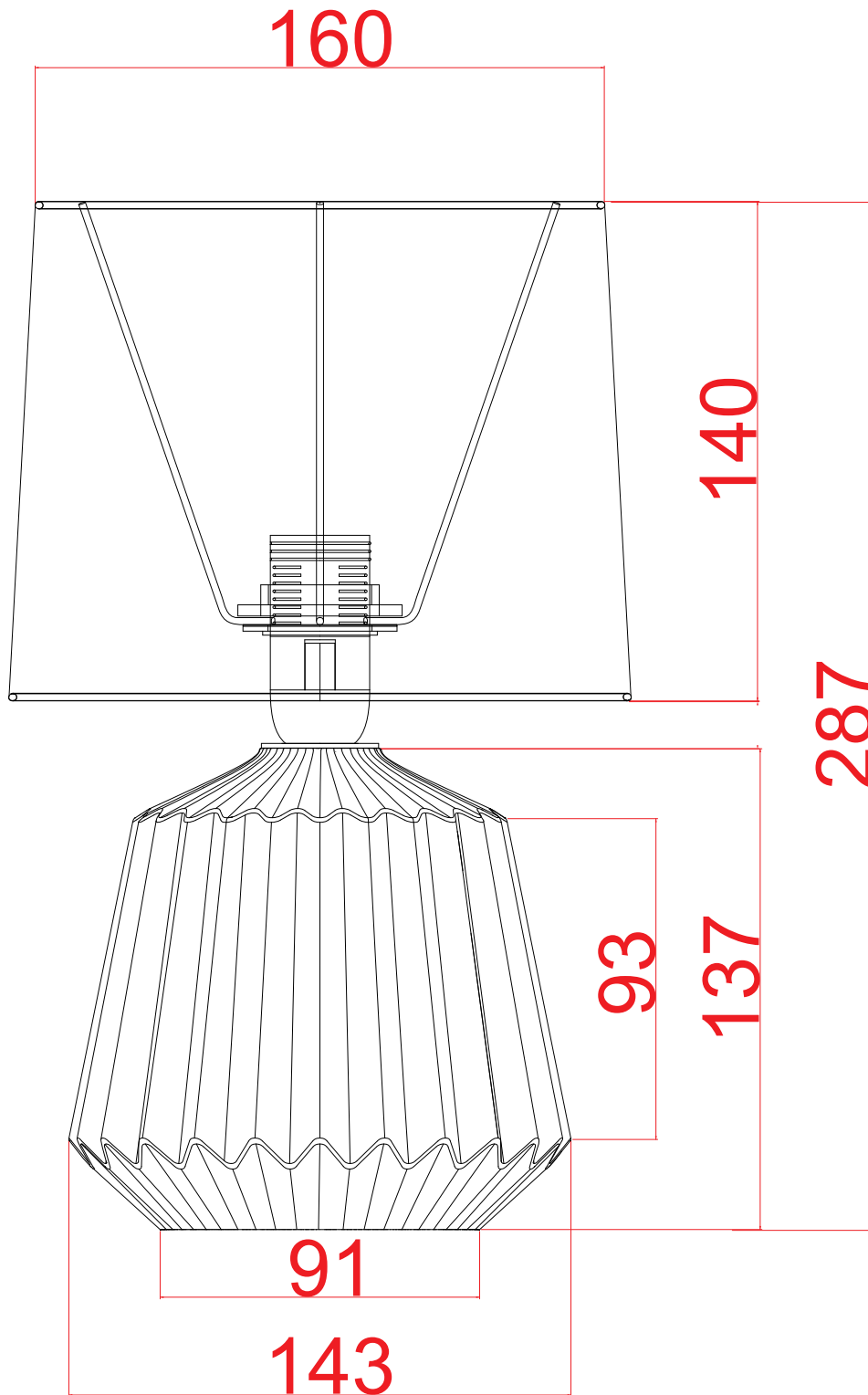

CERTIFICATION



CONTACT