



LIGHT SOURCE DATA

- 2 x 40W Max E14 SES (required)
- Lamp direction - Indirect
- Lamp shape - Standard
- Non-dimmable

DIMENSION DATA

- Height 200mm
- Diameter 100mm

- Weight .22kg

SPECIFICATION

- Manufacturer warranty for 2 years from date of purchase
- Black
- IP20
- In-line On/Off Switch
- Class II - Double Insulated, No Earth
- 240V
- Assembly required? No
- 1.3m length cable from base to plug
- CE Marking, UKCA Marking, Energy Efficient, Energy Saving

CERTIFICATION



CONTACT

www.firstchoicelighting.co.uk

info@firstchoicelighting.co.uk

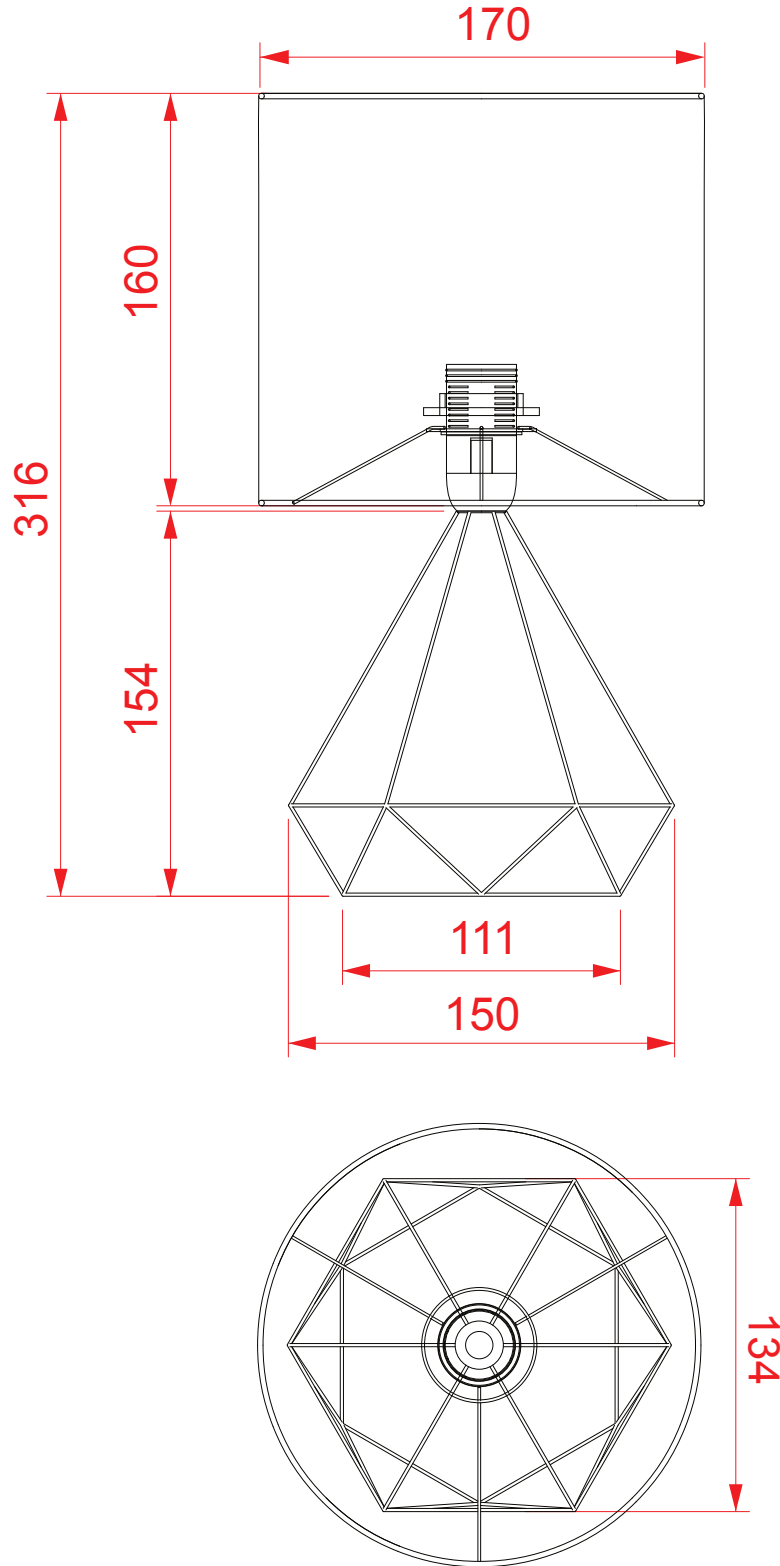

CERTIFICATION



CONTACT

www.firstchoicelighting.co.uk

info@firstchoicelighting.co.uk