

Hinkley Lighting - Palma - HK-PALMA-S-BU - Burnished Bronze Clear Glass IP44 Outdoor Wall Light



REFERENCE

- SKU: FCL-26080
- Supplier SKU: HK-PALMA-S-BU
- Barcode: 5024005012160

DESCRIPTION

Palma charmingly blends European elegance with timeless touches of the classic pineapple motif. Sophisticated and modern, Palma is infused with a dash of old-world glamour. This enduring design creates a balanced sensation of both refinement and ease as part of its overall appeal.

CATEGORY

- Brand: Hinkley Lighting
- Family: Palma
- Category: Outdoor Lighting / Wall / Decorative

APPEARANCE

- Base: Burnished Bronze
- Shade: Clear Glass

DIMENSION

- Height: 368mm
- Width: 203mm
- Depth: 243mm
- Weight: 2.5kg

LIGHT SOURCE

- Lamp included: No
- Lamp detail: 60W Max E27 ES (required)
- Dimmable
- Energy class: Not applicable
- Switch: No

SPECIFICATION

- Ingress protection: IP44
- Class: Class I - Single Insulated, Earthed
- Voltage: 240V

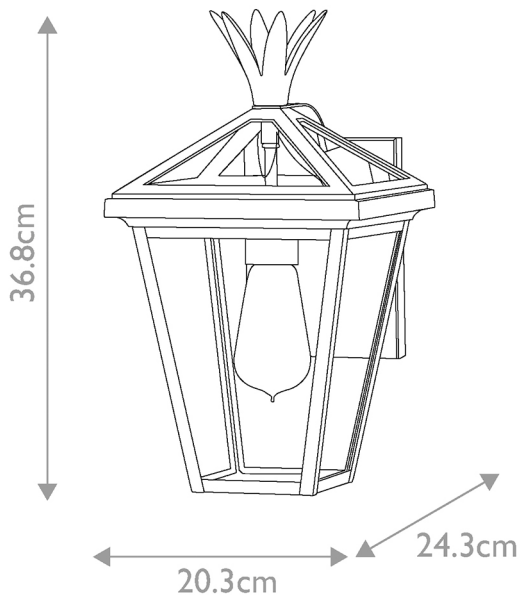

CONTACT