

Pair of Brushed Chrome & Opal Glass 3 Light Semi Flushes



## LIGHT SOURCE DATA

- 6 x 60W Max E14 SES (required)
- Lamp direction - Indirect
- Lamp shape - Standard
- Dimmable
- Energy class: Not applicable

## DIMENSION DATA

- Height 315mm
- Diameter 423mm
  
- Weight 2.68kg

## SPECIFICATION

- Manufacturer warranty for 2 years from date of purchase
- Brushed chrome plate and opal glass
- IP20
- No
- Class I - Single Insulated, Earthed
- 240V
- Assembly required? No
- CE Marking, UKCA Marking, Energy Efficient, Energy Saving

## CERTIFICATION



## CONTACT

[www.firstchoicelighting.co.uk](http://www.firstchoicelighting.co.uk)

[info@firstchoicelighting.co.uk](mailto:info@firstchoicelighting.co.uk)

# FCL-55842X2

Pair of Brushed Chrome & Opal Glass 3 Light Semi Flushes

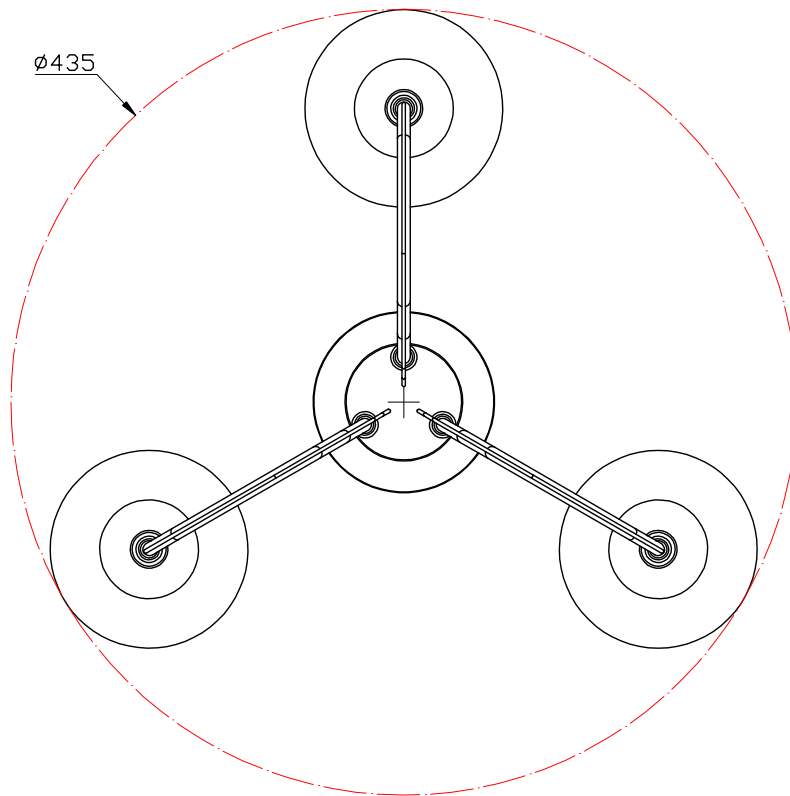
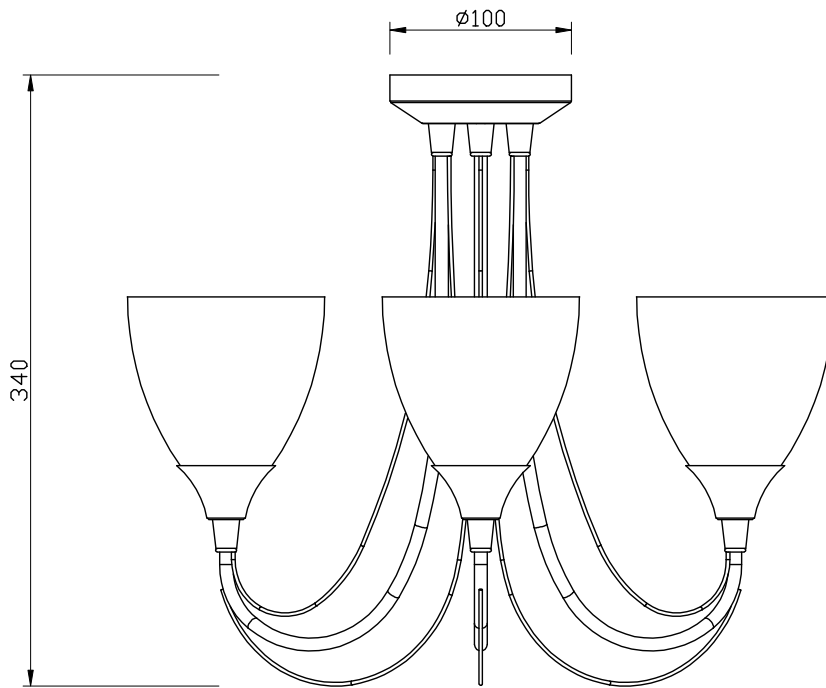

## CERTIFICATION



## CONTACT

[www.firstchoicelighting.co.uk](http://www.firstchoicelighting.co.uk)

[info@firstchoicelighting.co.uk](mailto:info@firstchoicelighting.co.uk)