



LIGHT SOURCE DATA

- 3 x 60W Max E14 SES (required)
- Lamp direction - Indirect
- Lamp shape - Standard
- Dimmable
- Energy class: Not applicable

DIMENSION DATA

- Height 315mm
- Diameter 423mm

- Weight 1.34kg

SPECIFICATION

- Manufacturer warranty for 2 years from date of purchase
- Brushed chrome plate and opal glass
- IP20
- No
- Class I - Single Insulated, Earthed
- 240V
- Assembly required? No
- CE Marking, UKCA Marking, Energy Efficient, Energy Saving

CERTIFICATION



CONTACT

www.firstchoicelighting.co.uk

info@firstchoicelighting.co.uk

Brushed Chrome & Opal Glass 3 Light Semi Flushes

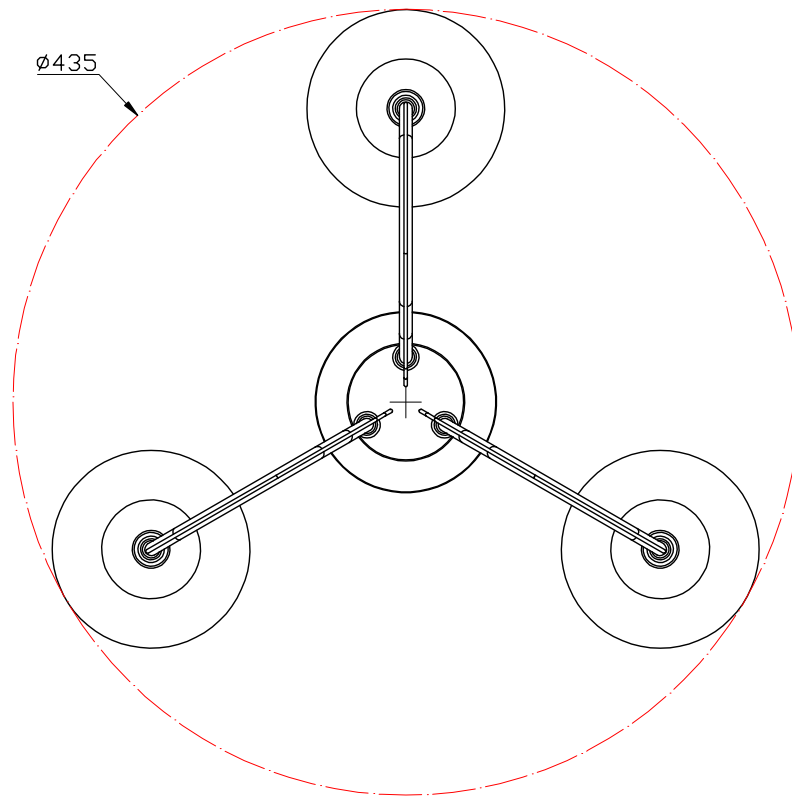
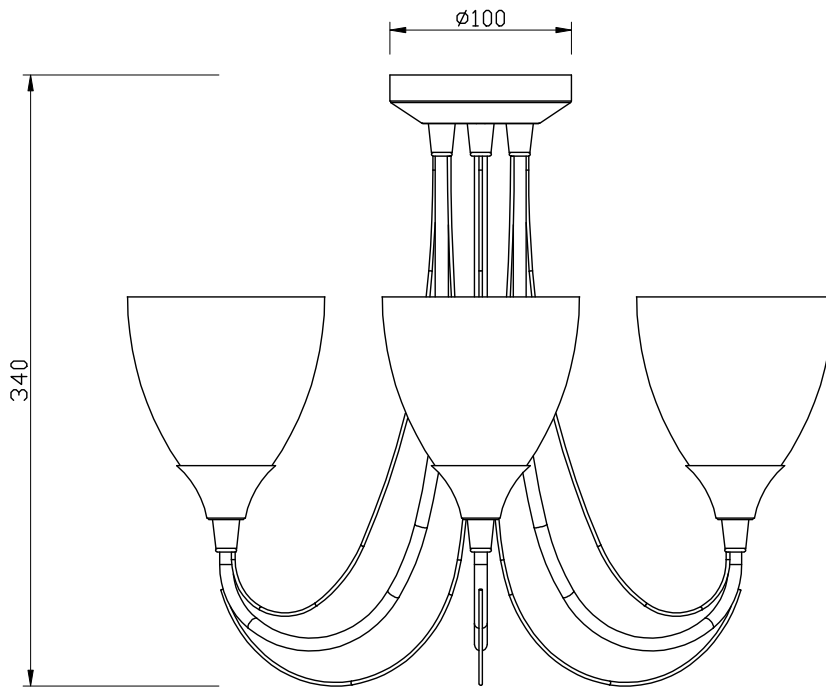

CERTIFICATION



CONTACT

www.firstchoicelighting.co.uk

info@firstchoicelighting.co.uk

ISSUE DATE 16/02/2023

PAGE 2