

Pair Grey Tripod Table Lamp with Grey Fabric Shade



LIGHT SOURCE DATA

- 2 x 40W Max B22 BC (required)
- Lamp direction - Indirect
- Lamp shape - Standard
- Non-dimmable
- Energy range: A++, A+, A, B, C, D, E

DIMENSION DATA

- Height 520mm
- Diameter 260mm
- Weight 1.05kg

SPECIFICATION

- Manufacturer warranty for 2 years from date of purchase
- Grey and grey cotton
- IP20
- Lampholder On/Off Switch
- Class II - Double Insulated, No Earth
- 240V
- Assembly required? No
- UKCA & CE Marking, Energy Efficient, Energy Saving

CERTIFICATION



CONTACT

www.firstchoicelighting.co.uk

info@firstchoicelighting.co.uk

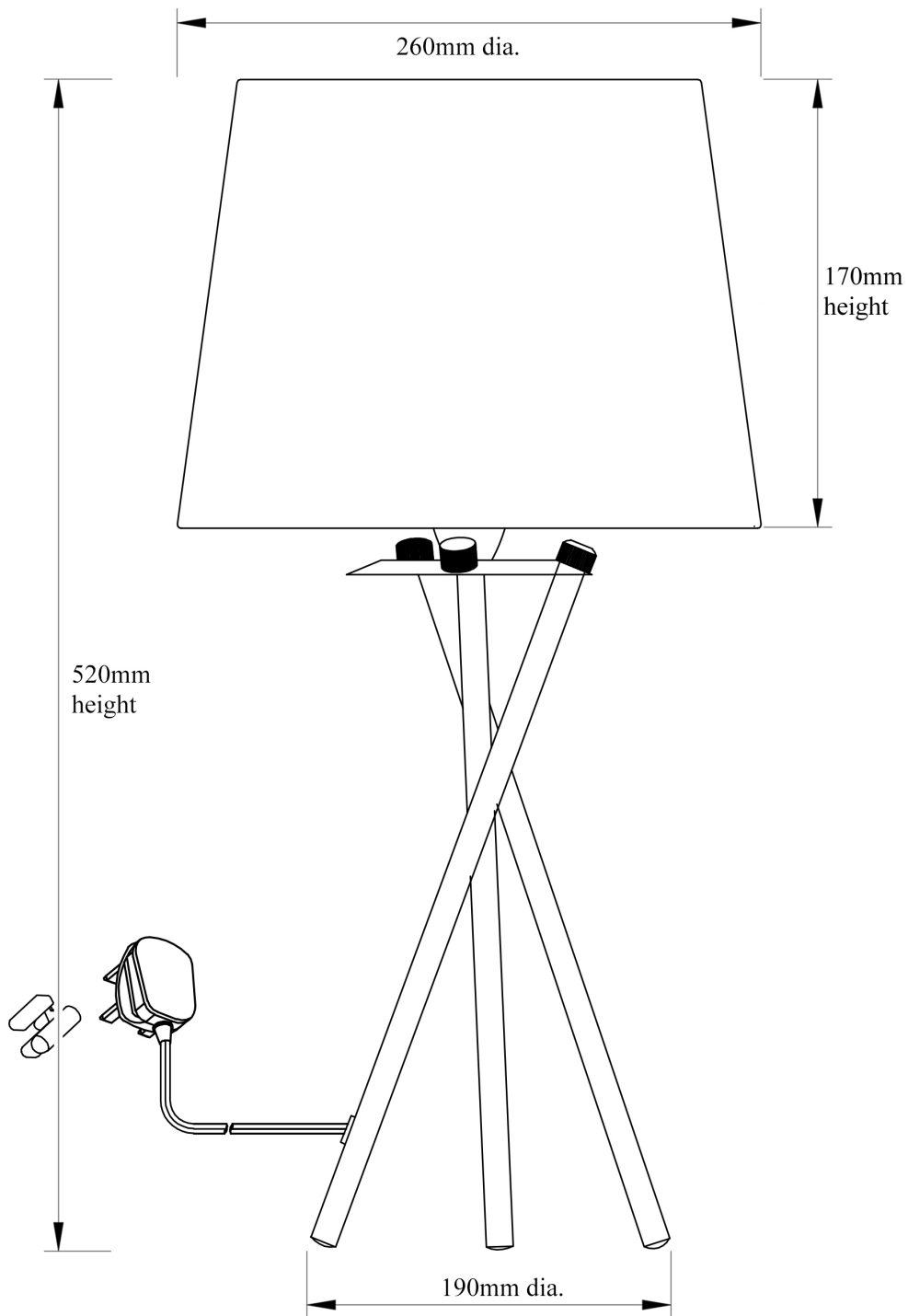

CERTIFICATION



CONTACT

www.firstchoicelighting.co.uk

info@firstchoicelighting.co.uk