

# Semi Flush Fitting

## INSTRUCTION MANUAL

### Safety Warnings

- This product is only suitable for connection to a 220-240V~50Hz supply in accordance with current IEE wiring regulations, and should be installed in accordance with local building regulations. It is for indoor use only, and is **not** suitable for a bathroom location.
- Before installing your light fitting always switch off the mains supply, and remove the appropriate fuse or switch off the appropriate circuit breaker before commencing installation. Ensure that no one else has access that would enable the supply to be inadvertently reconnected.
- **This is a Class 1 product and must be Earthed.** The terminal blocks are supplied according to requirements of the fitting.
- Never fit bulbs of a higher wattage than those specified on the label (as these may cause overheating and damage the fitting)
- This product contains delicate parts – be careful during handling and maintenance to avoid breakage.
- If you are in any doubt about your competence please consult a qualified electrician.
- If any modification is made it will invalidate the warranty and may render the product unsafe.

### Care Information

Allow 10 minutes to cool before replacing, adjusting or cleaning.

Clean with a dry cloth only. Do not use liquid or abrasive cleaners on this product.

### Assembly/ User Instructions

#### Before you start

Please read these instructions carefully before fitting and retain for reference. Check the packaging and make sure that you have all the required parts. Follow each assembly step in order to prevent incorrect assembly. Ensure that the product is fully assembled as illustrated before use.

#### The Light pack contains:

Light fitting  
Fixing pack

#### The following tools may be required:

Selection of cross and flat head screwdrivers.  
Electric drill and assorted drill bits.  
Wire strippers.  
Hex Key

**These assembly diagrams are intended as a guide – if in doubt consult a qualified electrician.**

1. Decide on the position of the light fitting, or remove existing light fitting. Take a note of the position of the electrical connections. Ensure there is a solid mounting surface, preferably a wooden joist or joist bridge to support the weight of the light fitting.
2. To reduce packaging, the product is supplied with the arms folded and it is necessary to reattach the arms before attaching the product to the ceiling. Turn the arms anticlockwise 5 times to ensure the cable will straighten when the arms are fully assembled. Then pull any excess cable out through the ceiling cover (A).. Then attach the arms to the stem with the supplied hex screws and key (B).
3. Remove the fixing bracket (C) from the ceiling cover and attach to the ceiling using the screws provided. Ensure there is a joist at the point of fixing to support the weight of the product. Take care to avoid damaging any concealed wiring and pipes.
4. Support your fitting and connect the house wiring to the terminal block - see expanded wiring diagram (D).  
**NOTE: This is a Class 1 product and MUST be earthed.**
5. This product has “L” shaped fixing holes to allow easy fixing to the ceiling strap. Locate the “L” slots (E) around the small screws (F) on the fixing bracket (A). Rotate the ceiling cover to attach the product to the bracket. Tighten the screws to secure. Take care not to trap any wiring.
6. Fit the bulbs (G - not supplied). **NOTE: Never fit bulbs of a higher wattage than those specified on the label (as these may cause overheating and damage the fitting).**
7. Turn on the power and test.

# Assembly/ User Instructions Continued

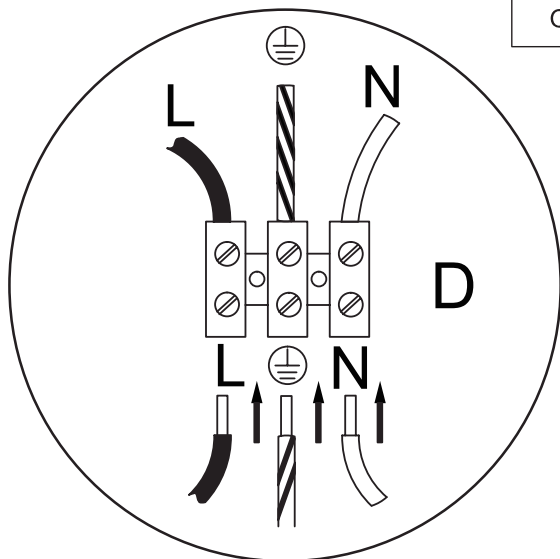
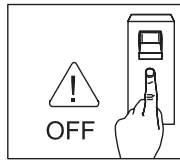

Class I

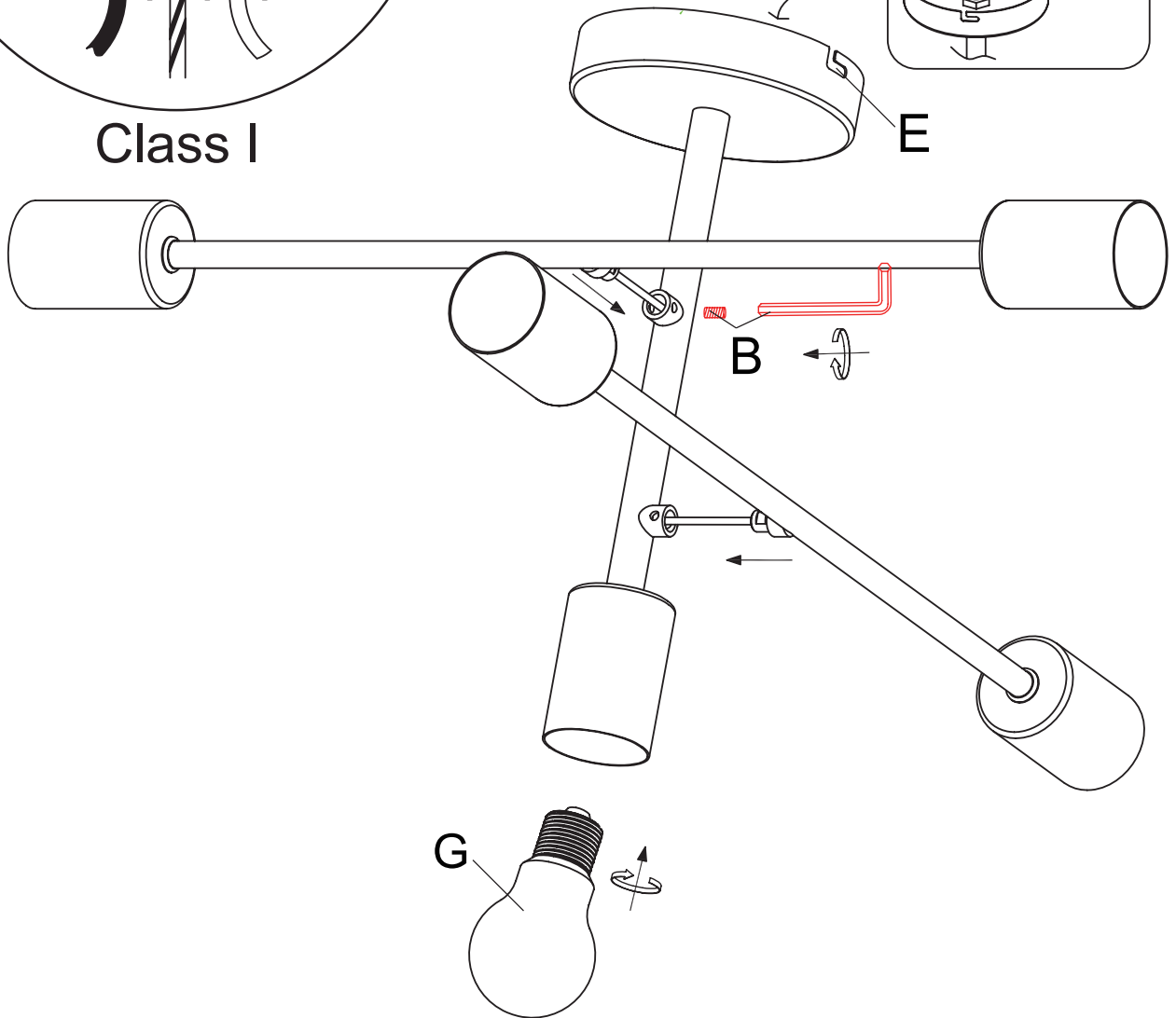
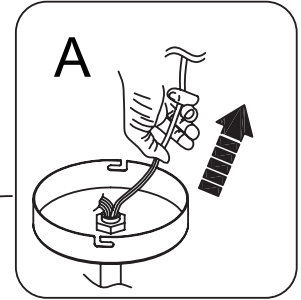
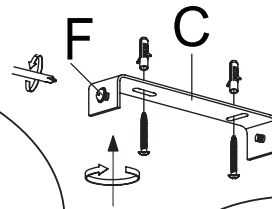

- (EN) Scan QR code for multi-language
- (FR) Scannez le code QR pour plusieurs langues
- (ES) Escanee el código QR para varios idiomas
- (PL) Zeskanuj kod QR dla wielu języków
- (DE) Scannen Sie den QR-Code nach mehreren Sprachen
- (IT) Scansiona il codice QR per multilingua



UK Manufacturer: BH17 7BY  
 EU Manufacturer: 1 Gnarrenburg, 27442